

<b>Elco Elettronica s.r.l.</b>
<b>HW 18650-1500mAh specification</b>

**1.0 Normal performance**

Model		HW 18650 -1500		
Case material		Steel with Nickel		
Standard capacity (20°C)		1500 mAh		
Rated voltage		3.20V		
Max.Charge voltage		3.65V		
Cut-off voltage		2.30V		
Max.Charge current		1C <sub>5</sub> A		
Max. constant discharge current		5 C <sub>5</sub> A		
Diameter		65.0±0.5mm		
Height		18.0±0.5mm		
Weight (Approx.)		about 42 g		
Impedance (at 1000Hz.)		≤45mΩ		
Cycle life		2000		
Charge method (CC/CV)	Standard	CC	0.2C	3.65V cut off
		CV	3.65	0.05C cut off
	Rapid	CC	1C	3.65V cut off
		CV	3.65	0.05C cut off
Operate temperature	Charge	0°C~45°C		
	discharge	0°C~45°C		
	storage	0°C~45°C		

**2.0 Drawing for single cell**

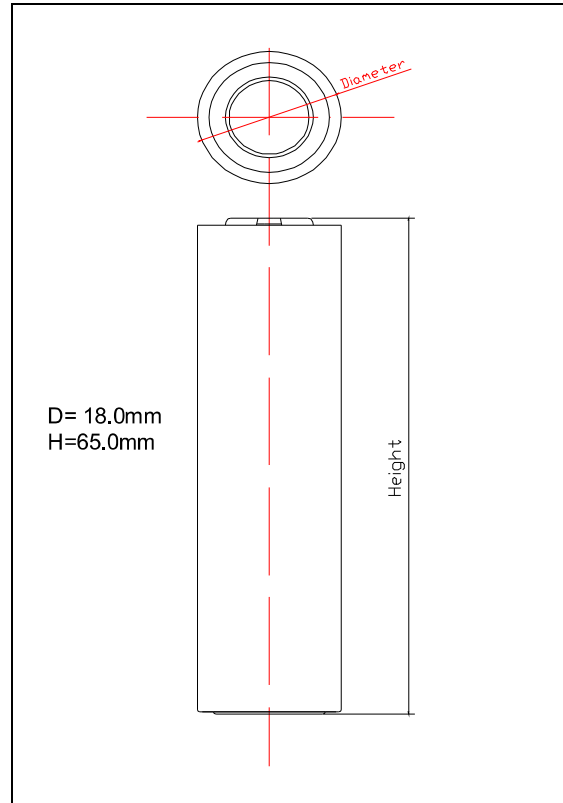

**3.0 charge and discharge curve**

0.2C、1C charge curve

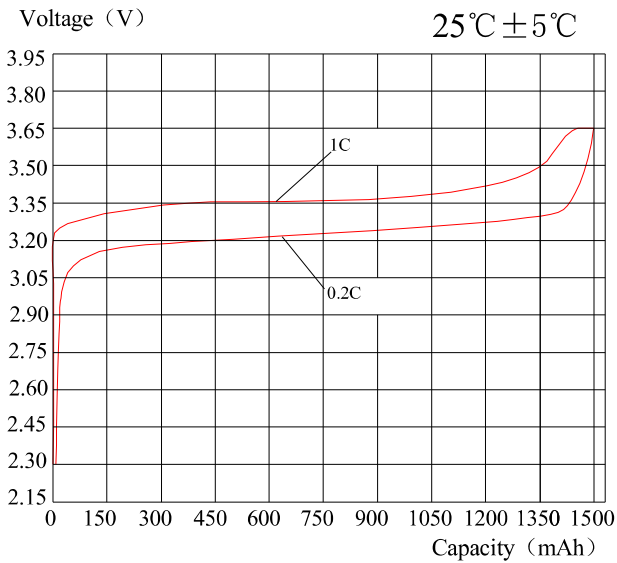

Diploid discharge curve

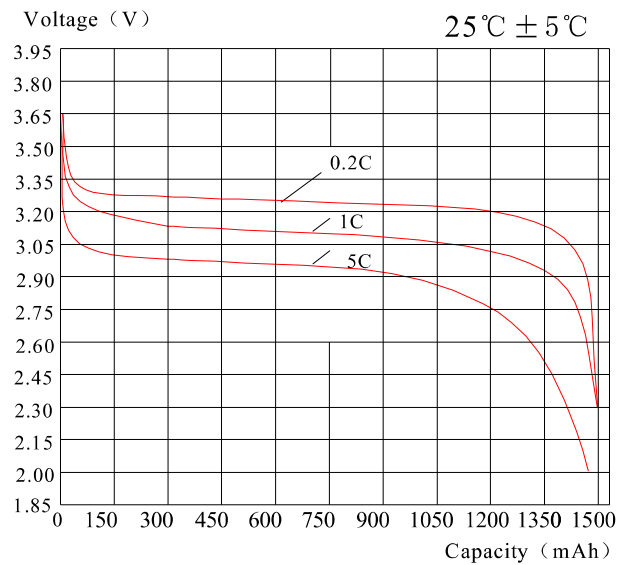

**Elco Elettronica s.r.l.**

**HW 18650-1500mAh specification**

**4、 Testing Conditions**

4.1 Standard Testing Condition

Without special , all the tests of this specification shall be done under temperature:  $25^{\circ}\text{C}\pm 2^{\circ}\text{C}$ , humidity:  $65\%\pm 20\%\text{RH}$ , air pressure: 101.325kPa.

4.2 Standard Charge Method

Under conditions of 4.1, charge at  $0.5\text{ C}_5\text{A}$  to 3.65V, then charge with constant voltage 3.65V to the current less than  $0.02\text{ C}_5\text{A}$

4.3 Quik Charge Method

Under conditions of 4.1, charge at  $1\text{ C}_5\text{A}$  to 3.65V, then charge with constant voltage 3.65V to the current less than  $0.01\text{ C}_5\text{A}$

**5、 Electrical Property**

No	Item	Standard	Testing Method
1	Normal Temperature Electrical Property	DischargeCapacity/Nominal Capacity $\times 100\%$ Charge and discharge curves should be smooth.	Under condition of 4.1, charge according to 4.2 method (without special explanation, all tests below follow the same charge method, lay aside for 10min, discharge at $0.5\text{C}$ to the end voltage 2.0V; test three cycles, if one cycle up to the standard, battery has passed the test.
2	Discharge Rate	DischargeCapacity/Nominal Capacity $\times 100\%$	Under condition of 4.1, charge with standard charge method, discharge at $0.2\text{C}$ 、 $0.5\text{C}$ 、 $1\text{C}$ 、 $2\text{C}$ 、 $3\text{C}$ 、 $4\text{C}$ 、 $5\text{C}$ 、 $6\text{C}$ to the end voltage 2.0V。

**Elco Elettronica s.r.l.**

**HW 18650-1500mAh specification**

3	Normal Temperature Charged Retention	Residual Capacity > 85% Resume capacity < 90% Open-circuit Voltage Reduce rate < 3% Internal Resistance Increase Rate ≤ 20%	Test the initial status and capacity of battery, lay aside the battery for 28 days after Standard charging, test final status of battery; discharge at 0.2C to 2.0V, test the final capacity; charge with 0.2C and discharge with 0.2C, test the resume capacity; test three cycles, if one cycle up to the standard, battery has passed the test.
4	Cycle Life	Capacity ≥ Nominal Capacity × 70%	Test the initial status and capacity of battery, charge at 0.5C and discharge at 0.5C, test the final capacity after 1500 cycles.
5	Storage	0.2C discharge time: After 3 month storage ≥ 4.5h; After 6 month storage ≥ 4.25h; After 12 month storage ≥ 4h	Test the initial capacity of battery, charge to 3.65±0.05V, test the battery status before storage, storage 3 month, 6 month, 12 month, charge at 0.2C and discharge at 0.2C, test three cycles, get the maximum charging time record.

**6、Environment Property**

Test Items	Test Methods	Test Standard
6.1 Constant Heat & Humidity	Charge the battery with 4.2 or 4.3 charge methods, put cells into 40°C ± 2°C (90%~95%RH) constant temperature and humidity box, and put on hold for 48hrs, then take cell out, put on hold for 2 hrs at room temperature. Check the exterior appearance, discharge at 1 C <sub>5</sub> mA to cut-off voltage	1. Exterior appearance has no deformations, corrosion, smoke or explosion 2. Discharging time no less than 36min.
6.2 Vibration Test	Charge the battery with 4.2 or 4.3 charge methods, install battery on the vibration table, adjust the equipment according to the following vibration and amplitude frequency. From X,Y,Z three directions in 10~55Hz sweep vibration to sweep for 30min with the sweep frequency speed rate at 1oct/min: vibration frequency: 10Hz~30Hz displacement amplitude(single): 0.38mm; amplitude frequency: 30Hz ~55Hz displacement amplitude(single): 0.19mm.	1. Exterior appearance has no apparent stain, leakage, smoke and explosion. 2. Single battery cell voltage no less than 3.2V
6.3 Crash Test	After experimented with 6.2 specified methods, fix the battery through the fixture from the three perpendicular X,Y,Z axes respectively to the vibration table, follow the requests below to adjust the acceleration, pulse duration time for crash test: pulse peak acceleration: 100m/s <sup>2</sup> , collision frequency per min: 40~80 pulse duration time: 16min	1. Exterior appearance has no apparent stain, leakage, smoke and explosion. 2. Single battery cell voltage no less than 3.2V

**Elco Elettronica s.r.l.**

**HW 18650-1500mAh specification**

	collision frequency: 1000±10.	
6.4 Drop Test	After experimented with 6.3 specified methods, let the sample drop from the height of 1000mm to 18-20mm wooden sheet on the cement surface. Drop from the positive and negative pole in X, Y, Z (6 directions) once respectively. Then do the charge and discharge cycles at 1C <sub>5</sub> A until the discharging time is no less than 51min. Have at least three cycles	Battery cell has no electrolyte leakage, smoke or explosion

**7、 Safety Test**

Test Items	Test Methods	Test Standards
1. Heavy Impact Test	Place the battery cell on the impact platform, and let the steel column of Φ15.8mm 9.1kg right above the battery center, then drop it from the height of 610mm to impact the cell. Cell - distortion is allowed	Battery cell has no fire or explosion
2. Extrusion Test	Place the battery cell between the surface of the extrusion equipment, with the cylindrical battery cell mandrel parallel to the extrusion plane, and gradually increase the pressure to 13kN, hold for 1min	Battery cell has no fire or explosion
3. Thermal Shock	Place the cell in the electric blast oven with speed of 5±2°C/min to increase the room temperature to 130±2°C, hold for 30mins	Battery cell has no fire or explosion
4.(3C/10V) Over-charge Test	Discharge at 0.2C <sub>5</sub> mA until cut-off voltage, then connect the battery positive and negative poles to the constant voltage power supply. Adjust the current to 3 C <sub>5</sub> mA, voltage of 10V, and then charge at 3 C <sub>5</sub> mA to the battery until the output voltage is no less than 10V, then continuous charge for 1hr or until the voltage has stopped increasing	Battery cell has no fire or explosion
5. Short-circuit Test	Place the battery connector with thermocouples into the dume hood, short-circuit the positive and negative electrodes with copper wire (total resistance of circuit not higher than 50mΩ). Monitor the temperature of the battery cells in the process, and end the test when the temperature is 10°C lower than the peaks	1. Battery cell has no fire or explosion 2. Highest temperature < 150°C
6. Nail Test	Place the battery connector with thermocouples into the dume hood, with a Φ3.0mm stainless steel pin at the speed of 20-40mm/s to nail the largest surface center of the battery.	Battery cell has no fire or explosion